

1568A Power Amplifier

1568A



Features:

- High efficiency
- Easy service access
- Low installation costs
- Simple circuitry
- High and low impedance inputs
- 70V and 25V outputs
- Low cost per watt
- Built-in speaker protection
- Stable under all load conditions
- Underwriters approved
- Low power consumption
- Outstanding quality
- Inputs and outputs may be safely paralleled

The 40 watt 1568A power amplifier is an important element in the Altec Lansing "1500 Series" of "Building Block" public address amplifiers, pre-amplifiers and accessories. It has been carefully engineered for simple, high-speed installation in order to reduce labor costs. For maximum reliability, the circuitry has been designed to withstand "hot switching" and other punishment which the amplifier may be given by non-technical operators.

This 40 watt amplifier is only 8 $\frac{3}{4}$ " in height and will mount in either a standard Relay Rack or Cabinet or the Altec 12894 or 12895 cabinet. Outstanding features include continuously variable gain control, power switch, pilot light and fuse mounted on a hinged front panel where they are readily accessible. The complete circuitry of the amplifier and its controls is exposed for easy servicing when this panel is opened. All connections are made to the rear of the amplifier through simple barrier-type terminal blocks and a pre-wired three conductor power cord.

The input facility of the amplifier provides direct connection to the input potentiometer for unbalanced high and low impedance sources with a minimum of 0.9 volt signal strength. Independent input terminals connect to an octal socket which will accept the 15095 Matching Transformer for balanced low impedance lines up to a level of +8 dbm. These two inputs can be used simultaneously for greater facility.

The amplifier will accommodate output loads of 4, 8, 16 and 124 ohms; the corresponding drive voltages being 12.6, 18, and the popular 25 and 70 volts. Circuit design provides exceptional stability under varying conditions of line voltage, tube characteristics and long unloaded speaker lines of large capacitance. A low frequency cut-off in the amplifier gives protection for driver speakers. Four steps provide from 0 to 22 db of attenuation at 250 cycles.

The 1568A is ideal for all types of public address, paging, music distribution and sound reinforcement systems requiring moderate power handling capacity.



A Division of *LSV* Ling Altec, Inc.

1515 S. Manchester Ave., Anaheim, Calif.
New York

SPECIFICATIONS

Gain:	65 db
Input Sensitivity:	0.9 volts
Power Output:	40 watts at less than 2% thd 40-20,000 cps
Frequency Response:	± 1 db 5-30,000 cps, ± 4 db 1-100,000 cps
Input Impedance:	70,000 ohm potentiometer
Source Impedance:	150 or 600 ohms with 15095 plug-in transformer
Load Impedance:	4 (12.6V), 8 (18V), 16 (25V), 124 (70V) ohms ungrounded
Output Impedance:	Less than 15% of nominal load impedance
Noise Level:	80 db below rated output
Controls:	Volume control, continuously variable composition
Power Supply:	117 volts, 50/60 cps, 125 watts
External Power Available:	117 volt AC receptacle on chassis
Tubes:	2-6CG7, 2-6CA7/EL34, 1-5U4GB
Dimensions:	8 $\frac{3}{4}$ " H, 19" W, 7 $\frac{3}{4}$ " D
Color:	Green
Weight:	22 lb.
Special Features:	For 1500 series applications. This amplifier has a two-stage Hi-Pass filter for protection of horn loaded drivers.

ACCESSORIES

15095 Plug-in Line Transformer

See Amplifier Accessories sheets for relay racks, mounting cabinets, and other amplifier accessories.

ARCHITECTS AND ENGINEERS SPECIFICATIONS

The power amplifier shall be of the rack mounting type measuring not more than 8 $\frac{3}{4}$ " H, 19" W, and 7 $\frac{3}{4}$ " D. The amplifier shall include a continuously variable volume control of composition material, together with pilot light, fuse holder, and on-off switch. Any amplifier utilizing a common "radio type" volume control and not including these features shall not be acceptable under these specifications.

The power output shall be 40 watts with less than 2% total harmonic distortion over the frequency range of 40 to 20,000 cycles. The frequency response shall be ± 1 db 5 to 30,000 cycles, or ± 4 db 1 to 100,000 cycles. The noise level shall be 80 db below rated output. The overall gain of the amplifier shall be no less than 65 db. The output impedance shall be less than 15% of nominal load impedance. The load impedance shall be 4, 8, 16 (25V) and 124 (70V) ohms ungrounded. The input sensitivity shall be 0.9V rms for rated output. The input impedance shall be 70,000 ohm volume control, and the source impedance 150 or 600 ohms with 15095 plug-in transformer. The amplifier shall operate from 117V 50/60 cycles and shall not draw more than 125 watts from the primary circuit. The tube complement shall consist of two 6CG7, two 6CA7/EL34, one 5U4GB. The unit shall be finished in green and shall weigh in the order of 22 pounds.

Any power amplifier which does not have a tertiary winding in the output transformer for the proper regulation of the feedback circuit shall not be deemed acceptable under these specifications.

The amplifier shall be Altec Lansing Model 1568A.

NOTICE
We recommend that you obtain your Altec products from factory trained authorized Altec Sound Contractors and Distributors. This will assure you of proper installation, a continuing source of knowledgeable advice, service, and quick warranty protection.



1568A AMPLIFIER

OPERATING INSTRUCTIONS



SPECIFICATIONS

Type:	Power Amplifier
Gain:	65 db
Input Sensitivity:	0.9 volt
Power Output:	40 watts at less than 2% thd 40 to 20,000 cps
Frequency Response:	± 1 db, 5-30,000 cps; ± 4 db, 1-100,000 cps
Input Impedance:	70,000 ohm potentiometer
Source Impedance:	150 or 600 ohms with 15095 Plug-in Transformer
Load Impedance:	4 (12.6 v), 8 (18 v), 16 (25 v), 124 (70 v) ohms ungrounded
Output Impedance:	Less than 15% of nominal load impedance
Noise Level:	80 db below rated output
Controls:	Volume control, continuously variable, composition
Power Supply:	117 vac, 50/60 cycles, 125 watts
External Power Available:	117 volt ac receptacle on chassis
Tubes:	2-6CG7, 2-6CA7/EL34, 1-5U4GB
Dimensions:	8 $\frac{3}{4}$ " high, 19" wide, 7 $\frac{3}{4}$ " deep
Color:	Dark green
Weight:	22 lbs.
Special Feature:	Two stage high-pass-filter for protection of horn loaded drivers
Accessory:	15095 Plug-in Transformer



GENERAL DESCRIPTION

The 1568A Amplifier is a rack mounted, AC operated power amplifier intended for use in sound reinforcing, paging, music distribution, or any application requiring low distortion, wide frequency range, complete stability with any type of load, reliability of operation, ease of servicing or low cost.

At 40 watts distortion is less than 2% at any frequency from 40 to 20,000 cycles per second. The frequency response is within 4 db of mid range value from 1 cycle per second to 100 KC. The feedback circuit is designed for stability under conditions of varying line voltage, varying tube characteristics, and all types of loads including long unloaded speaker lines having considerable capacitance. The tubes are conservatively operated under CCS (continuous commercial service) ratings of their manufacturer, and the amplifier has been shown to withstand "hot switching" and other punishment which might be encountered in the hands of untrained operators.

The amplifier occupies five units of rack space (8 $\frac{3}{4}$ "") and has a hinged front panel on which are mounted the power switch, fuse, pilot light and a continuously variable gain control. All circuitry is completely accessible for servicing when the front panel is open. The amplifier is equipped with a 3-wire power cord terminating in a 3-pin cap. Input and output terminals are provided in the form of barrier-type terminal blocks mounted on the outer surface of the chassis.

INPUT CONNECTIONS

The 1568A Amplifier is equipped with two pairs of input connections. Terminals 1 and 2, connecting directly to the input potentiometer, are provided for unbalanced high impedance sources, and to bridge unbalanced low impedance lines having a signal voltage of 0.9 volt or higher.

Terminals 3 and 4 connect to a standard octal socket which accommodates the accessory plug-in transformer. With the 15095 Transformer, balanced or unbalanced lines of 150 or 600 ohms up to a level of +15 dbm may be connected to input 3-4. The octal socket is normally connected for 500/600 ohm operation; 150 ohms impedance may be obtained by strapping the terminals in accordance with the diagram shown on the schematic.

OUTPUT CONNECTIONS

Outputs accommodate nominal loads of 4, 8, 16 and 124 ohms, the corresponding full-drive output voltages being 12.6, 18, 25 and 70 volts.

Speaker Matching: Use the output tap which most nearly equals the total speaker impedance. If the load impedance falls between two output terminal values, favor the terminal of lower impedance.

70 Volt Line: The 70 volt distribution system permits connection to a large number of speakers, each to operate at its own power level as required, without the necessity for computing impedances. In this system each speaker is equipped with a transformer containing a number of taps rated in terms of power, and the tap is selected which gives the power desired for that speaker. The total of the power settings for all speakers should be equal to or less than the amplifier system power rating. The 1568A Amplifier is equipped with outputs to drive both a 70 volt line and a 25 volt line.

Protection of Horn Loaded Drivers: Driver loudspeakers coupled to horns are used in paging or voice reinforcing systems where excellent intelligibility is required in the presence of high noise levels, effects of wind, and other disturbances. When a loudspeaker system dividing network is not available the diaphragm of the driver loudspeaker may be protected from low frequency power by the use of the R-C low frequency cut-off filter in V1 grid circuit (see schematic). As shipped, capacitors C1 and C2 are strapped out. By cutting one or both of these straps attenuation is introduced as shown in the table, depending upon the impedance of the source.

Effect of High Pass Filter

Source Impedance	Strapping	250	500	1000	2000 cps
100,00 ohms	One strap cut	-6.5	-3	-1	-0.2 db
	Both straps cut	-16	-8	-3.5	-1.2 db
Low	One strap cut	-13	-8	-3.5	-1.2 db
	Both straps cut	-22	-12	-4.2	-1.5 db

CONTROLS

The only controls on this amplifier intended for normal operation are the power switch and the gain control. Potentiometer P2, which establishes the bias voltage for the output tubes, is set at the factory and will probably not require readjustment over a long period of operation. If, due to ageing of the rectifier, the bias voltage should drop below the value indicated on the schematic, it will be desirable to reset P2. Measurement should be made with an accurate voltmeter, at a line voltage of 117 volts, and with no signal applied.

**1568 A AMPLIFIER
TYPICAL FREQUENCY RESPONSE**

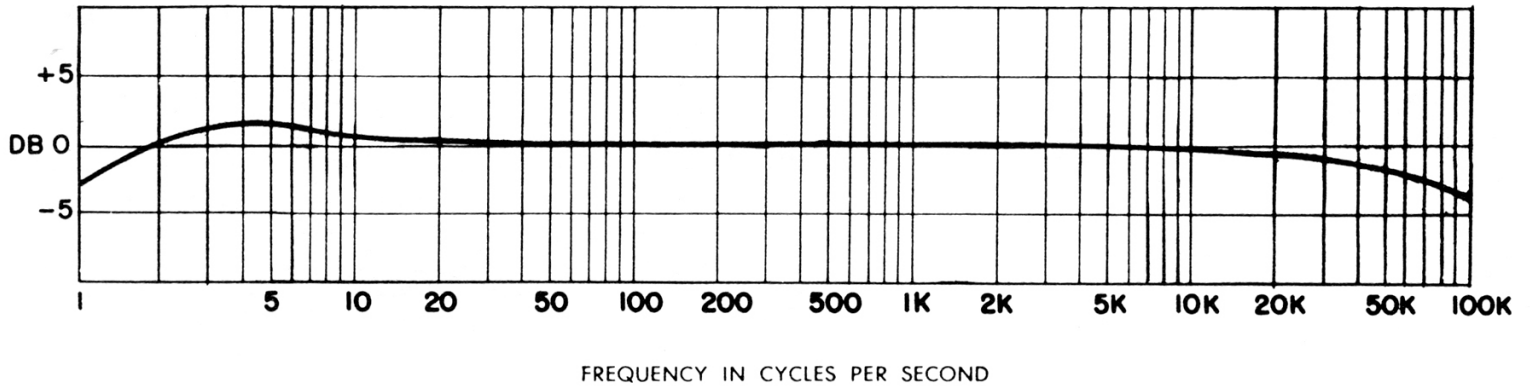

**1568 A AMPLIFIER
FREQUENCY VS POWER AT SELECTED T.H.D.**

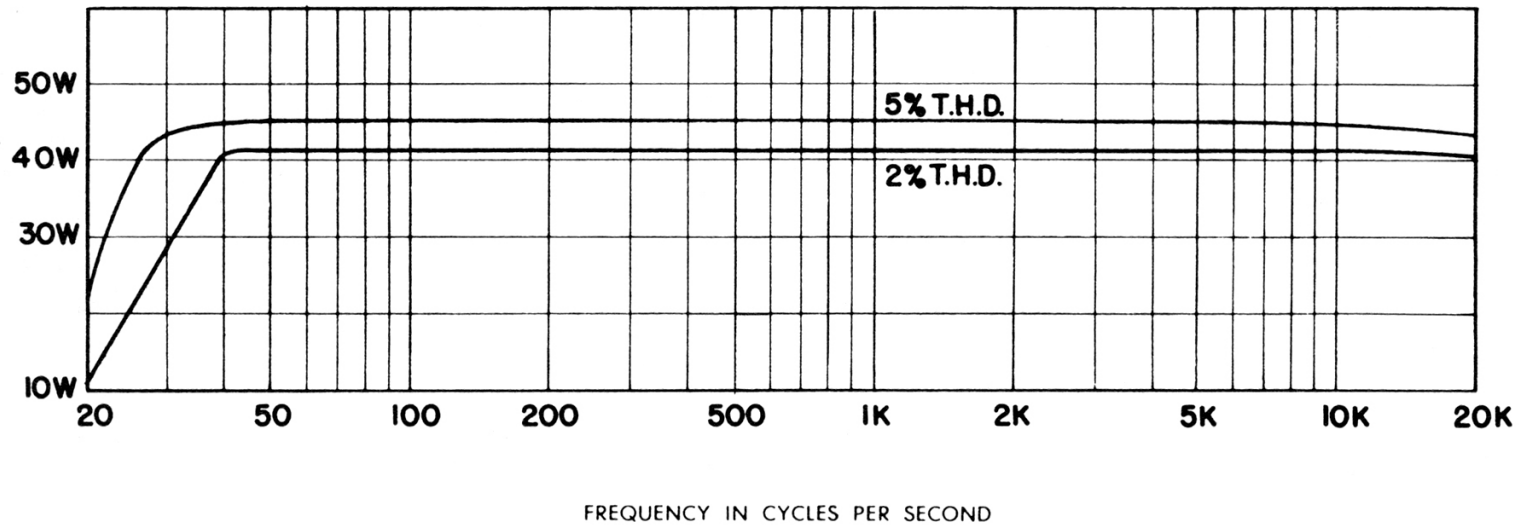

PARTS LIST

C1	.002 mfd. $\pm 10\%$ ceramic disc Erie 811-202	R14, 15	100 ohms $\pm 10\%$ 1/2 watt
C2	.001 mfd. $\pm 10\%$ ceramic disc Erie 811-202	R16	600 ohms 5 watt Ohmite Brown Devil
C3	50 mfd. 6 V. Mallory TT	R17	1500 ohms $\pm 1\%$ 1/2 watt deposited carbon
C4	.000047 mfd. $\pm 10\%$ ceramic disc Erie 831-470	R20	220 ohms $\pm 10\%$ 1/2 watt
C6, 7	.22 mfd. 400 V. Sprague 4TMP-22	R19	4700 ohms $\pm 10\%$ 1 watt
C8	50 mfd. 50 V. Mallory TC	P1	200,000 ohms Altec Lansing 12435
C9, 10	40 x 40 mfd. 500 V. Mallory FP288	P2	5000 ohms Mel-Rain Type FFF-1
C11	.5 mfd. 400 V. CD PJ4P5	F1	3 amp. 3 AG fuse
R1, 8, 12, 13	100,000 ohms $\pm 10\%$ 1/2 watt	PL1	Mazda #44
R2	47 ohms $\pm 1\%$ 1/2 watt deposited carbon	S1	Altec Lansing 12536 switch
R3	1800 ohms $\pm 10\%$ 1/2 watt	SR1	Selenium Rectifier GE1N1491
R4	100,000 ohms $\pm 10\%$ 1 watt	J1	Alden 402 ACEHG receptacle
R5, 6	68,000 ohms $\pm 10\%$ 1/2 watt	T1	Peerless 16432
R7	1 megohm $\pm 10\%$ 1/2 watt	T2	Peerless 6288
R9	18,000 ohms $\pm 10\%$ 1 watt	V1, 2	6CG7 vacuum tube
R10, 11, 18	47,000 ohms $\pm 10\%$ 1 watt	V3, 4	6CA7/EL34 vacuum tube
		V5	5U4GB vacuum tube

NOTE:
AMPLIFIER IS SHIPPED WITH C1 & C2 STRAPPED
OUT. WHEN USED WITH DRIVER LOUDSPEAKER
WITHOUT NETWORK CUT STRAPS AS REQUIRED

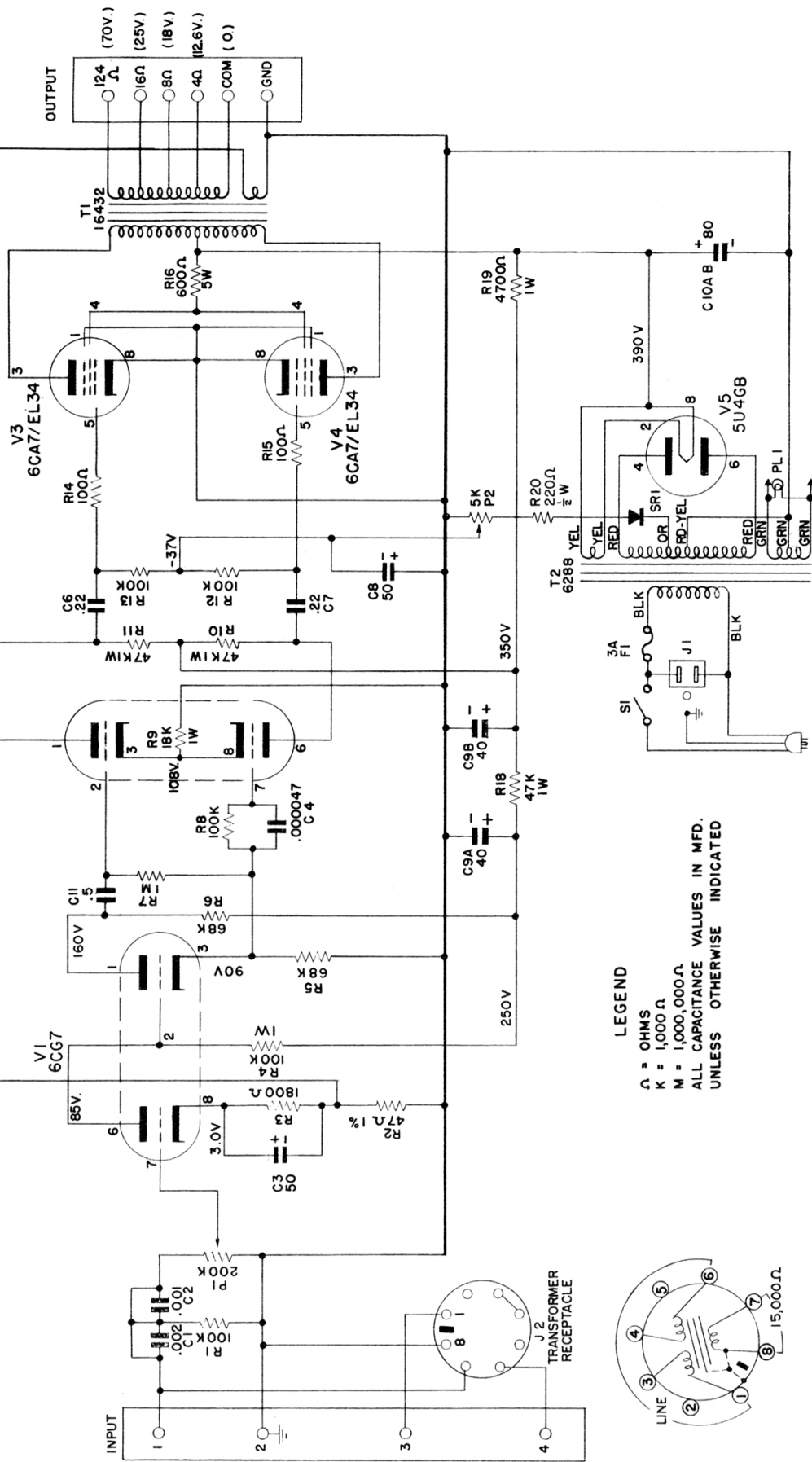

LEGEND
 Ω = OHMS
 K = 1,000 Ω
 M = 1,000,000 Ω
 ALL CAPACITANCE VALUES IN MFD.
 UNLESS OTHERWISE INDICATED

15095 TRANSFORMER IMPEDANCES
 LINE 150 Ω
 STRAP J2 600 Ω
 1-4, 3-6
 3-4

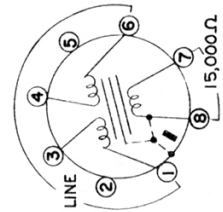

FIRST MADE FOR TOLERANCES EXCEPT AS NOTED FRACT. & 1/8" DEC. & .005" HOLE SIZES & TO 1/16" & .001 OVER 1/16" & .005 ANGULAR \pm 1/16"

ISSUE	APPROVED	DATE	CHANGE
1	✓	6-65	
2	✓	9-28-68	5 WAS 22 (C11)
3	✓	11-25-68	DELETED C5
4	✓	7-19-68	15095 TRANS. WAS 4665 TRANS.
5	✓	1-21-68	5U4GB TRANS. WAS 4665 TRANS.
6	✓	1-21-68	5U4GB TRANS. WAS 4665 TRANS.

ALTEC
 ANAHEIM, CALIFORNIA
1568 A AMPLIFIER
 SCHEMATIC

DR. BY G.J.S. 6344 - 6
 ALTEC INC.

ALTEC LANSING 1568 A AMPLIFIER