

250 T3 Control Console

FOR ALL STEREO AND UNIVERSAL FUNCTIONS

250 T3

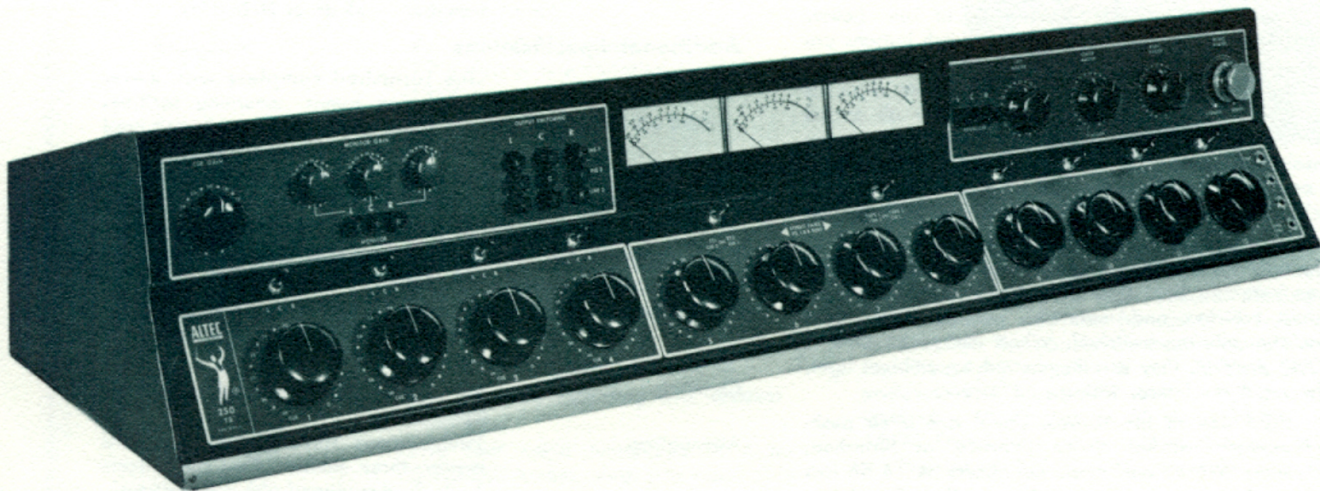

Features

- Flexibility of design
- Solid state circuitry throughout
- Frequency response = 0.5 dB, 30 to 20,000 Hz.
- Microphone input to line output gain = 99 dB
- Three channel stereo operation
- Four dual inputs with ganged mixer controls for two channel turntable and tape stereo
- Key selector TT1 and TT2 or Tape 1 or Tape 2 with "auto-cue" on dual inputs
- Eight single mixers with cue positions on four
- Choice of single, dual or three channel operation
- Console fully wired for three channels
- 12 connected inputs
- Microphone level or "high level" on any input
- 9475A plug-in type Amplifiers used in all positions except turntable and high level
- Low impedance mixing
- Push button switches for flexibility in connection of Left, Center or Right channels to any outgoing line
- Ambient lighted push-button switches and illuminated meters
- Three channel monitoring by headphone or speakers
- Microphone inputs 150 or 600 Ω
- RIAA standard equalization

The new, all solid state Altec 250 T3 Control Console, successor to the time tested and proven 250 SU, has been designed to fulfill the complex and exacting requirements of music centers, recording and broadcast studios, convention centers and all other high quality sound systems. The 250 T3 is universal in its design and provides the greatest flexibility of function of any contemporary console. Because of this new versatility, the console may be used in a small staffed, small city studio or, with the addition of extra amplifiers and accessory equipment, may be used to fulfill the requirements of a large studio.

The 250 T3 Console has twelve input positions. All of the input positions are equipped with "bus" switches and mixer control attenuators, providing a means of selecting and mixing ten of the twelve input lines. Eight of the input positions may be used for either high level or low level sources by inserting the proper Altec input device. Located above each mixer control attenuator is a three-position select or key switch which permits placing the output of the attenuator on Left, Center or Right channel.

One of the major innovations of the 250 T3 Console concerns the other four inputs. To satisfy two-channel stereo requirements, these four inputs have been designed as stereo pairs. These stereo pairs have "ganged" mixer controls which connect to the left or right busses when used. Two of these pairs are low-level, for turntables 1 and 2, and the other two are high-level for tapes 1 and 2. Each pair has a selector switch. One selects turntable 1 or turntable 2. Using the automatic cue system, when the switch is in TT1 position, TT2 is automatically on cue. In this position the second turntable can be set for immediate play. The same conditions are true when the switch is in TT2 position. The automatic cue system also applies to the other switch which selects tape 1 or tape 2. Four Altec 1579A equalized Phono Amplifiers are used on turntables 1 and 2 and four Altec 15095 Transformers are used for the stereo tape inputs.

An important feature of the 250 T3 Console is the design that eliminates a variety of amplifiers. The console is wired to accommodate the Altec 9475A Amplifier which is used in all console circuit positions as a preamplifier, booster amplifier or program amplifier.

All output circuitry for single-channel/single-line, two-channel/single-line, three-



A quality company of LTV Ling Altec, Inc.

1515 S. Manchester Ave., Anaheim, Calif. 92803
New York

channel/single-line, two-channel/two-line, three-channel/three-line, two-channel stereo, three-channel stereo and three-channel/two-channel stereo is included and wired. Mounting trays for the maximum number of plug-in units are installed and wired in the console. All input and output connections terminate at Western Electric type solder "strips" located inside the console housing.

An added feature of the 250 T3 Console is the nine push button output switches mounted on the front of the console. These switches give great flexibility in the connection of Left, Center and Right channels to outgoing lines. The nine switch buttons are located on three, three-switch button frames, which interlock and lockout within the frame. This allows any of the three channels to be placed on any of the three outgoing lines, or all of the channels to be placed on one outgoing line. With this arrangement, the console can be used as "mono" with all channels feeding one line, or if fully complemented, be used as three separate consoles, each capable of handling a program or audition function.

The lockout feature prevents one channel from being placed on more than one outgoing line at a time. Constant-loss networks feed the output switches and maintains constant levels and impedances as channels are switched. When the switch buttons are in the "ON" position, they are illuminated by ambient light, eliminating the need for lamps, wiring and power.

On the upper right side of the console panel are three push-to-lock, push-to-release switches. These switches, as furnished, are single frequency, speech and music equalizers. A 14 dB loss pad is built in with the equalizer function so that the simple equalizer and pad (see block diagram) can be replaced by the more sophisticated Altec 9061A or 9063B Program Equalizers if desired. These equalizers must be mounted externally.

Four monitor jacks are located on the console, one jack for each channel, Left, Center and Right. The remaining monitor jack picks up the Left and Right channels and may be used with stereo head phones. "ON-OFF" switches in the monitor lines permit listening to any channel without interference from the others. All three monitoring channels use isolation resistors in conjunction with transformers to protect the main program busses from a short circuit or a fault on a monitor line.

Standard Altec Amplifiers, such as the Model 9471A (20 Watt) or Model 9476A (8 Watt) are recommended as accessory units to the 250 T3 Console. These may be mounted in a standard equipment rack.

A compact, reliable, solid-state power supply, the Altec Model 542A, has been designed to furnish power to the amplifiers and for illumination of VU meters. The power supply, always a potential source of hum inducing flux fields, is mounted external to the console. The power supply is built into a separate housing which may be mounted to the table leg, or an adjoining wall. The Altec Model 542A Power Supply is connected to the 250 T3 Console by means of a five foot multiple conductor cable with a socket that mates with a plug in the console.

TECHNICAL DATA FOR 250 T3

Microphone input to Line Output Gain:	99 dB
Frequency Response:	±0.5 dB, 30 - 20,000 Hz.
Distortion:	0.5% THD, 30 - 15,000 Hz at +16 dBm output; 1% at +18 dBm output.
Signal to Noise Ratio:	70 dB (+17 dBm output with -55 dBm input).
High Level Channels Gain:	40 dB.
Frequency Response:	±1 dB, 20 - 15,000 Hz.
Distortion:	0.5% THD, 30 - 15,000 Hz at +16 dBm output; 1% at +18 dBm output.
Signal to Noise Ratio:	72 dB (+17 dBm output with -4 dBm input).

Source Impedances

Microphone Inputs:	150 or 600 Ohms.
Tape or Utility Inputs:	Up to 15,000 Ohms
Turntable Inputs:	47,000 Ohms.

Load Impedances

Line Outputs:	600 Ohms.
Headphone Outputs:	600 Ohms.
Monitor Outputs:	600 Ohms (Requires separate monitor amplifiers).
Turntable Gain:	74 dBvg at 1,000 Hz.
Frequency Response:	RIAA standard equalization.
Interchannel Crosstalk:	Less than -60 dB, to 10,000 Hz. Less than -55 dB at 20,000 Hz.

Additional Specifications

VU Meters:	One furnished complete with meter illumination lamps, mounting facilities and pads. (Second meter is required for stereo or two-channel/two-line operation. Third meter required for three-channel/three-line operation. Available separately as accessories).
Cable Terminations:	Internally mounted Western Electric L6A terminal-board.
Patch Panel:	All major circuits brought to jumpered-terminals for wiring out jacks, if required.
Channels:	one, two, or three, divided to two for stereo use.
Attenuators:	Twelve mixers. Three masters, one board master, three monitor. One cue (Mixers 1 - 2 - 3 - 4 equipped with cue positions).
Keys:	Ten three-position keys. Eight make their mixer-attenuator selectable to three busses: one connects turntables 1 or 2 dual attenuators to Land R busses, with center off position, one connects tapes 1 or 2 attenuators to L and R busses, with center off position. When the latter two switches are in position 1 or 2, signals from the opposite position are connected to cue bus.
Switches:	Pushbutton types with interlock and lockout action used for selection of line 1, line 2, and 3 for L, C, R channel outputs. Pushbutton types with push-to-lock, push-to-release action used for off-on switching of equalizers and for monitors (L, C, R channels). All buttons have channel designations, self-illuminated by ambient light in the "on" positions.
Equalizers:	Speech equalizers are incorporated in L, C, and R channels for bass cut-off at 500 Hz. Terminations provided for connection of external equalizers, if desired.
Headphone Jacks:	Four. One each for L, C, R channel monitoring; one for L, R (stereo) monitoring.
Amplifiers:	Solid-state, professional quality, plug-in type. One used in all positions except turntable preamplifiers. Input and output 150 or 600 Ohms balanced. Equalized phono preamplifiers used in turntable preamplifier positions.
Power Supply:	Completely enclosed cube for external mounting, with interconnecting cable and connector. Supplies regulated dc power to all amplifiers, and 6 V ac to all pilot lamps.
Panels:	Aluminum, standard Altec green, with characters etched, filled. Panels may be engraved when additional marks required.
Cabinet:	Hinged, two-slope control panels, dark green. Contains all equipment except power supply and monitor amplifiers.
Dimensions:	9½" H x 44" W x 15" D.

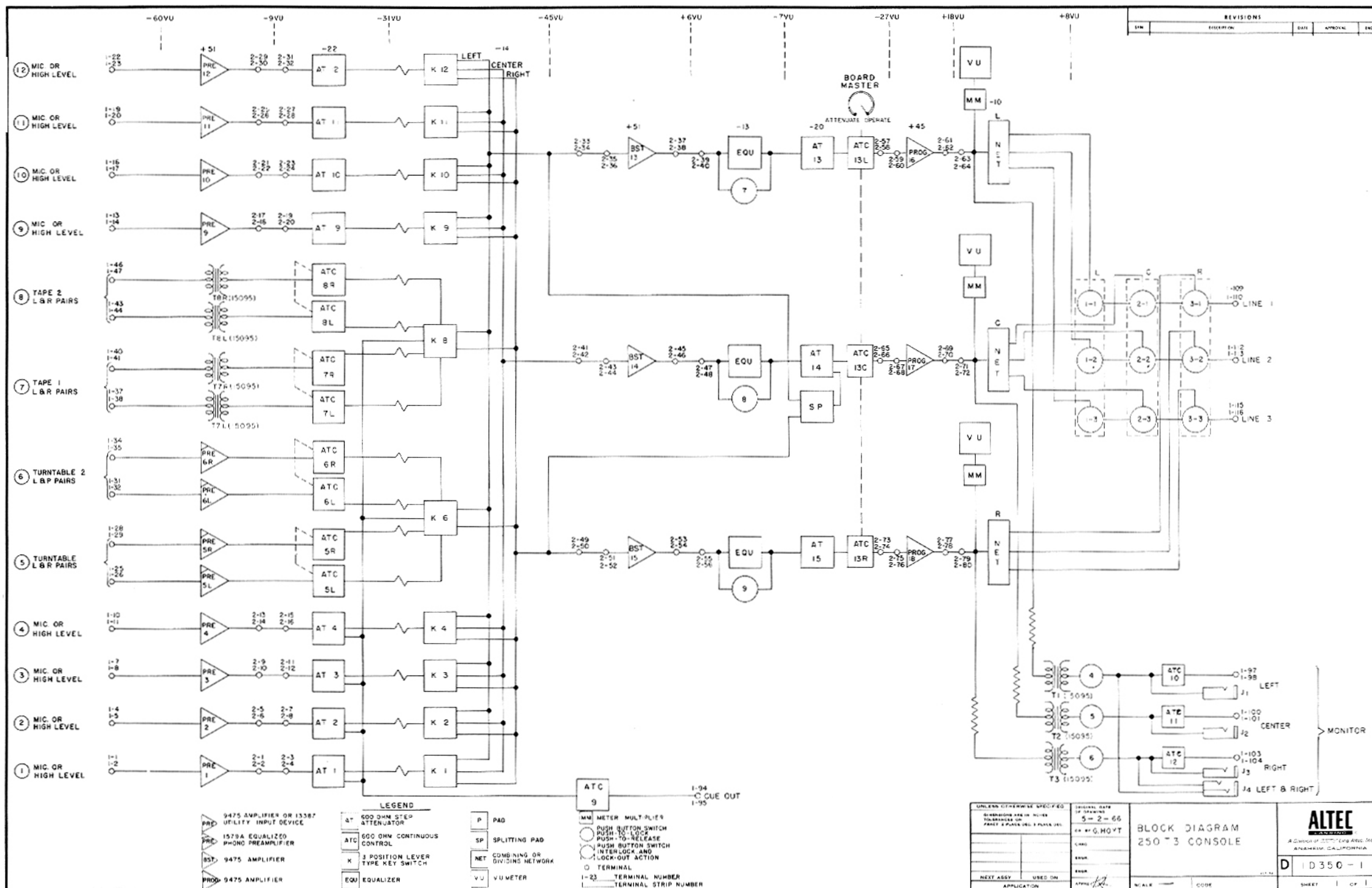

- Distortion:** Less than 1% THD from 20 to 20,000 Hz with +27 dBm output.
- Noise Level:** (unweighted, 10 to 25 kHz band pass). Equivalent input noise, -127 dBm (input unterminated).
- Overload Recovery Time:** 5 microseconds for 100% overload; continuous overload will not damage the amplifier.
- Controls:** None.
- Power Requirements:** 24V dc at 130 mA for +27 dBm output.
- Isolation:** Transformers on input and output.
- Circuit:** 3-stage, Class A, push-pull, direct coupled.
- Operating Conditions:** 85°C (185°F) maximum cabinet or turret temperature for continuous duty without derating.
- Heat Dissipation:** 3.12 Watts at +27 dBm output.
- Dimensions:** 4" H x 1 3/4" W x 9 1/2" D.
- Finish:** Light Gray baked enamel and cadmium iridized.
- Weight:** 3 pounds.
- Electrical Connections:** All electrical connections are made to a 15-pin plug on the rear of the 9475A Amplifier.
- Accessories:** 542A Power Supply, designed to power up to fourteen amplifiers at full output. 13225 Rack Mounting Assembly (accommodates fourteen units). 13401 Mounting Tray Assembly.



9475A AMPLIFIER

The 9475A Amplifier is a solid-state professional quality amplifier designed for use in recording, broadcasting and television studios. The high efficiency, extremely wide frequency response, low distortion, and virtual absence of hum and output noise enables the Altec 9475A Amplifier to exceed all requirements for that vital link in any first-line audio system, the preamplifier. Delivering 0.5 Watt, the 9475A Amplifier uses all silicon transistors which permit the amplifier to operate continuously at 85°C., (185°F.), without derating. Transistor circuitry plus specially designed, astatically balanced transformers, enables the 9475A to reach a noise figure of -127 dBm, with unterminated input. The total harmonic distortion is less than 1.0%, 20-20,000 Hz, with +27 dBm output. Overload Recovery Time is 5 microseconds for 100% overload.

9475A SPECIFICATIONS

- Type:** Preamplifier, booster amplifier, or program amplifier.
- Gain:** 45 dB. (input terminated).
- Frequency Response:** ±0.5 dB from 20 to 20,000 Hz.
- Source Impedance:** 150 or 600Ω, balanced or unbalanced (center tap on 600Ω).
- Load Impedance:** 150 or 600Ω, balanced or unbalanced (center tap on 600Ω).
- Output Impedance:** Less than 5% of nominal load.
- Power Output:** +27 dBm maximum from 20 to 20,000 Hz.

542A POWER SUPPLY

The Altec 542A Power Supply is a compact, reliable, solid-state power supply which furnishes regulated 24V dc to the 9475A Amplifiers, regulated 12V dc to the 1579A Amplifiers and 6V ac to the VU meter illumination lamps. The 542A Power Supply operates from a 120/240, 50/60 Hz input and at full load draws 95 Watts from the primary line. An "ON" "OFF" switch, the 2.5 Amp fuse in the 24V dc supply and the 1.0 A fuse in the primary line circuit are all located on the front panel. The unit is factory adjusted for 24 V dc output at 2.1 Amperes load and will hold within 4% of this voltage under any load condition up to 2.1 Amperes. Because the silicon rectifiers, transistors and zener diodes have current and voltage ratings in excess of operational requirements, the 542A Power Supply requires minimum maintenance.

REVISIONS			
SYM	DESCRIPTION	DATE	APPROVAL

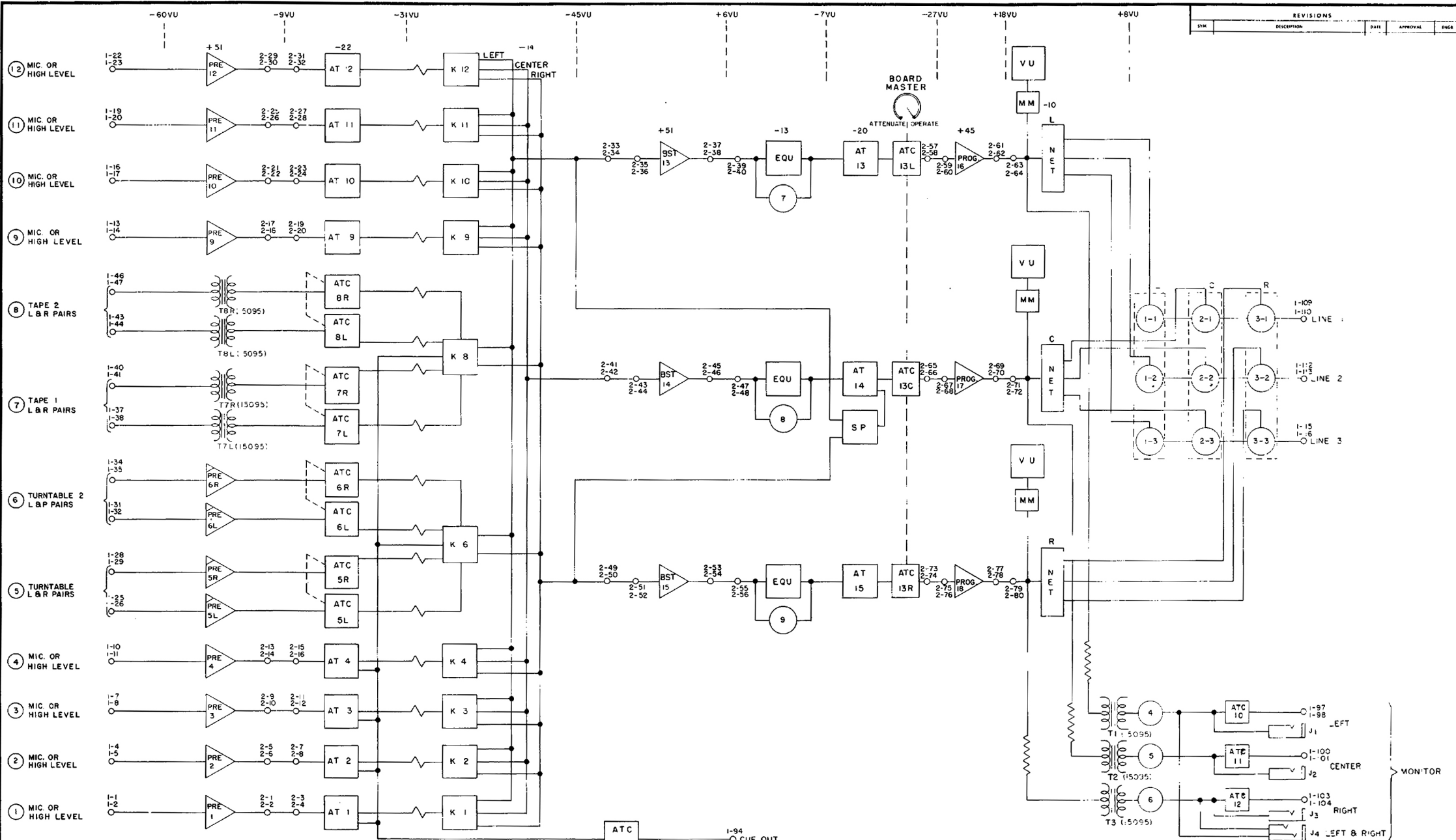

<p>PRE 9475 AMPLIFIER OR I3387 UTILITY INPUT DEVICE</p> <p>PRE I579A EQUALIZED PHONO PREAMPLIFIER</p> <p>BST 9475 AMPLIFIER</p> <p>PROG 9475 AMPLIFIER</p>	<p>AT 1800 OHM STEP ATTENUATOR</p> <p>ATC 600 OHM CONTINUOUS CONTROL</p> <p>K 3 POSITION LEVER TYPE KEY SWITCH</p> <p>EQU EQUALIZER</p>	<p>P PAD</p> <p>SP SPLITTING PAD</p> <p>NET COMBINING OR DIVIDING NETWORK</p> <p>VU VU METER</p>	<p>MM METER MULTIPLIER</p> <p>PUSH BUTTON SWITCH</p> <p>PUSH-TO-LOCK</p> <p>PUSH-TO-RELEASE</p> <p>PUSH BUTTON SWITCH INTERLOCK AND LOCK-OUT ACTION</p> <p>○ TERMINAL</p> <p>1-23 TERMINAL NUMBER</p> <p>1-23 TERMINAL STRIP NUMBER</p>
--	---	--	---

<p>UNLESS OTHERWISE SPECIFIED DIMENSIONS ARE IN INCHES TOLERANCES UNLESS OTHERWISE SPECIFIED ARE:</p> <p>FRONT & REAR DEC 3 MILS DEC</p>	<p>ORIGINAL DATE OF DRAWING: 5-2-66</p> <p>DR: R. G. HOYT</p> <p>ENGR:</p> <p>ENGR:</p> <p>ENGR:</p> <p>APPROVED: [Signature]</p>	<p>BLOCK DIAGRAM</p> <p>250 T3 CONSOLE</p> <p>SCALE: — CODE: —</p>	<p>ALTEC</p> <p>A Division of Teletek 4800, Inc.</p> <p>ANAHEIM, CALIFORNIA</p> <p>D 0350-1</p> <p>SHEET 1 OF 1</p>
--	---	--	--

542A POWER SUPPLY SPECIFICATIONS

DC Output:	24V, 2.0A regulated. 12V, .055A regulated.
AC Output:	6V 1.0A.
Output Ripple:	10 mV peak to peak on 24V output at 2.10A. 0.5 mV peak to peak on 12V output at 0.055A
Regulation:	4% no load to full load. 1.7% with ac line variation 105V to 135V.
Power Input:	95 Watts at full load 120/240V, 50/60 Hz.
Fuses:	1A in ac line. 2.5A in 24V dc output.
Rectifiers:	4 — 3A100 in bridge.
Regulators:	2 — Altec #40934 transistors 1 — Altec #40461 transistor 2 — 12V \pm 5% 2W Zener diodes 2 — 2A30 diodes
Dimensions:	6 $\frac{7}{8}$ " W x 5" H with feet, x 7 $\frac{1}{4}$ " D.
Mounting:	Shelf or wall mounting with bracket supplied.
Connections:	Five foot cable terminated in Jones S-306-CCT socket, plugs into Jones plug in 250 T3 Console.
Color:	Dark Green.
Weight:	10 lbs., 2 oz.

1579A EQUALIZED PHONO PREAMPLIFIER

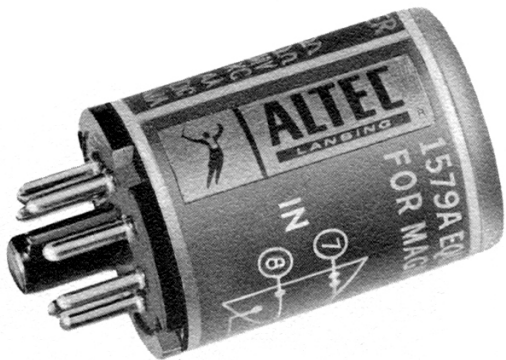

The 1579A Preamplifier is designed for use with magnetic phono pickups and will equalize them to meet the RIAA standard. Sensitivity is 5 millivolts for 70 millivolt output at 1 kHz. Output is +8 dBm at less than 0.5% THD. Input impedance is 47,000 Ohms and the power required is 12V dc at 11 mA. The 1579A plugs into a standard octal socket and has a diameter of 1 5/16" and a seated height of 1 13/16".

1579A SPECIFICATIONS

Sensitivity:	5 millivolts for 70 millivolts output at 1000 Hz.
Power Output:	+8 dBm at less than 0.5% THD.
Frequency Response:	Equalized to meet RIAA standard for magnetic phono pick-up.
Source Impedance:	47,000 Ohms.
Load Impedance:	600 Ohms.
Power Requirements:	12 V dc at 11 mA.
Mounting:	Standard octal socket.
Dimensions:	1 5/16" diameter x 1 13/16" seated height.
Weight:	1 ounce.

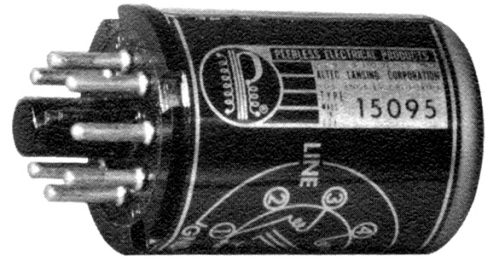

15095 LINE TRANSFORMER

The Altec 15095 Line Transformer is a miniature, plug-in line transformer used to provide isolation between the mixer buss and high level inputs. The 15000 Ω winding is used to bridge 600 Ω sources and can be operated from any impedance up to 15,000 Ω . The transformer has 30 dB of electromagnetic shielding. Frequency response is \pm 1 dB from 30 to 20,000 Hz; impedances are 150 or 600 Ω and 15,000 Ω ; a maximum operating level of +15 dBm above 30 Hz; +18 dBm above 40 Hz. The 15095 Transformer plugs into a standard octal socket and has a diameter of 1 5/16" and a height of 1 13/16".

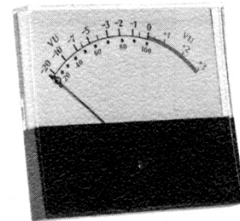

The 250 T3 Console is furnished with one 41222 VU Meter connected to the LEFT channel for single channel operation. For two-channel operation another accessory meter 41222 should be added to the RIGHT channel. For three-channel operation an additional 41222 Meter should be added to the CENTER channel. Meter multiplier, wiring and meter illumination is provided as part of the console.

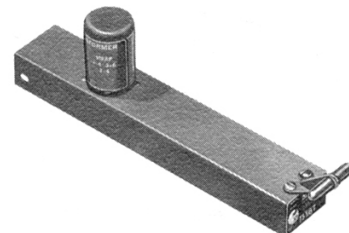

The 13387 unit is a Utility Input Device for high level input sources. The unit contains an Altec 15095 Isolation Transformer built on a "plug-in" chassis of the same size and dimensions as the 9475A Amplifier. The 13387 unit is designed for insertion into the standard 13401 Mounting Tray Assembly and is used for "bridging" a 150 or 600 Ohm line or matching a 15,000 Ohm line. The unit is cadmium plated with a dichromate dip and weighs 1 pound.

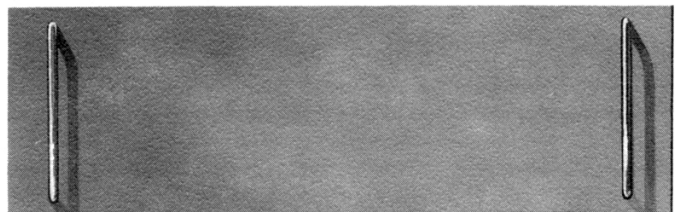

RACK MOUNTING FACILITIES

The Altec 13225 Rack Mounting Assembly is available for use in rack mounting of speech input equipment. The rack mounting assembly is drilled to accept nine, type 13401 Mounting Tray Assemblies for use with the Altec 9475A Amplifiers and the Altec 13387 Utility Input Device. The 13225 Assembly is for standard 19" rack or equipment cabinet mounting and occupies only 5¼" of panel space. The assembly has a "snap-in" removable front cover for instantaneous access to the units for test or service. The finish of the front cover is Dark Green, and the complete assembly weighs only 4 pounds.

The 13401 Mounting Tray Assembly is furnished as part of the 250 T3 Altec Control Console. It is also available separately to

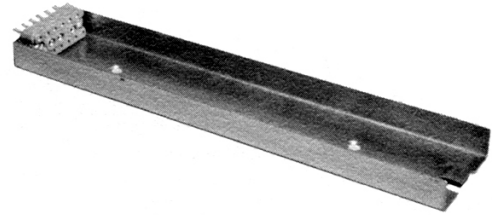

provide mounting and "plug-in" connection facilities for the 9475A Altec Amplifiers or the 13387 Utility Input Device, when mounted in the 13225 Rack Mounting Assembly. The 13401 assembly finish is cadmium plate with dichromate dip. The tray assembly is complete with "mating" female receptacle to accept the 9475A, 1579A and 13387 units. The tray measures 1¾" W x 7/8" H x 9" L (over terminals), and weighs ½ pound.

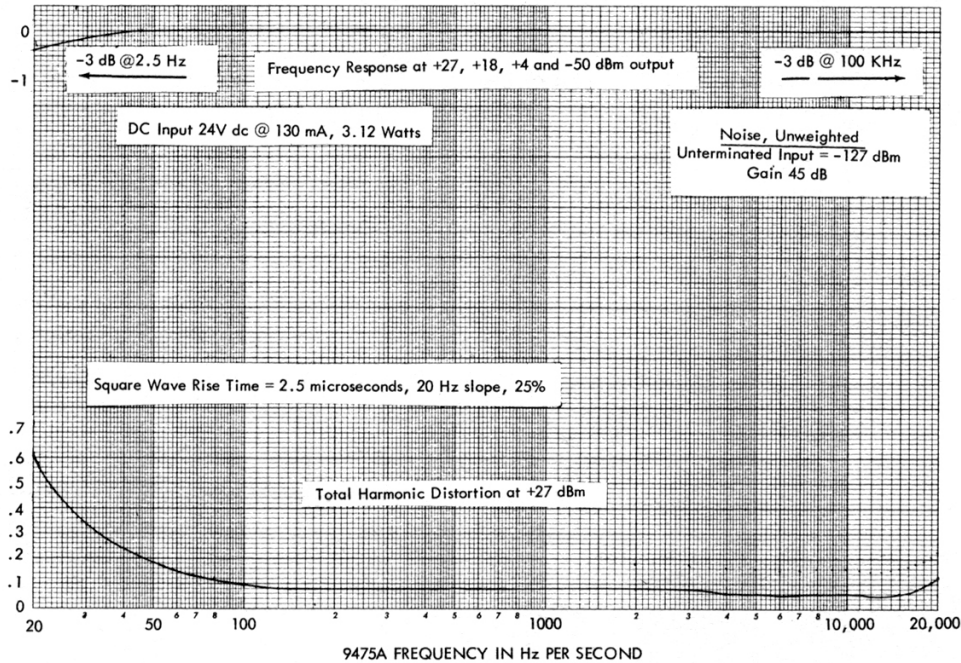

PLANNING INFORMATION

By completing the form below, the purchaser is assured of ordering the full complement of components to provide all facilities for the particular console.

1. 250 T3 Basic Altec Console _____ 1
2. 542A Power Supply _____ 1
3. 9475A Preamplifiers
 - (a) One for each microphone input (8 max.)
 - (b) One for each channel (3 max.).
4. 9475A Program Amplifiers (3 max.).
One for single-line/single-channel, two for two-channel/two-line or stereo and three for three-channel/three-line, or three-channel stereo or three-channel/two-channel stereo.
5. 13387 Utility Input Device
One for each high level input. Sum of 3a above and 5 cannot exceed 8.
6. 1579A Equalized Phono-Amplifiers
(a) 2 for each stereo turntable input (4 max.)
7. 15095 Transformers
(a) 2 for each stereo tape input (4 max.).
8. 41222 VU Meters: (1 furnished with basic console).
(Max. 3)
(a) 1 additional for two-channel operation
(b) 2 additional for three-channel operation